

Fig.9 Switching Time Measurement Circuit

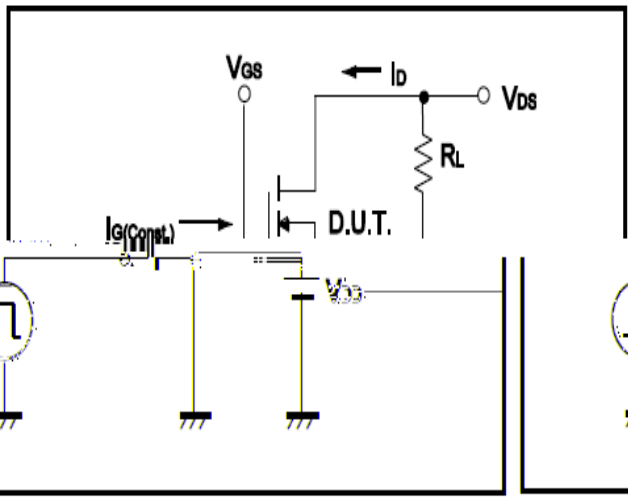

Fig.11 Switching Time Measurement Circuit

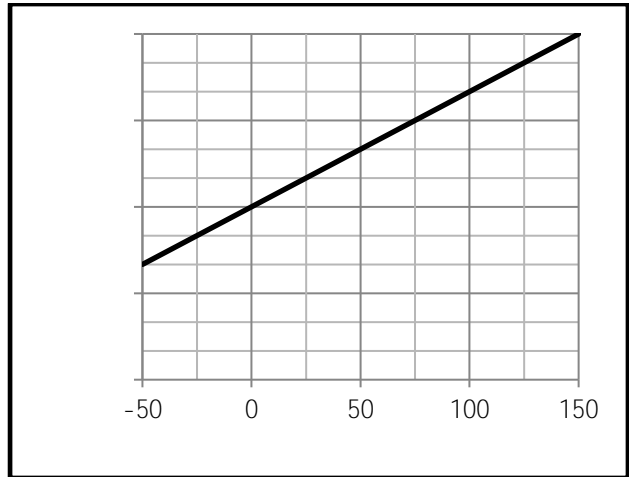
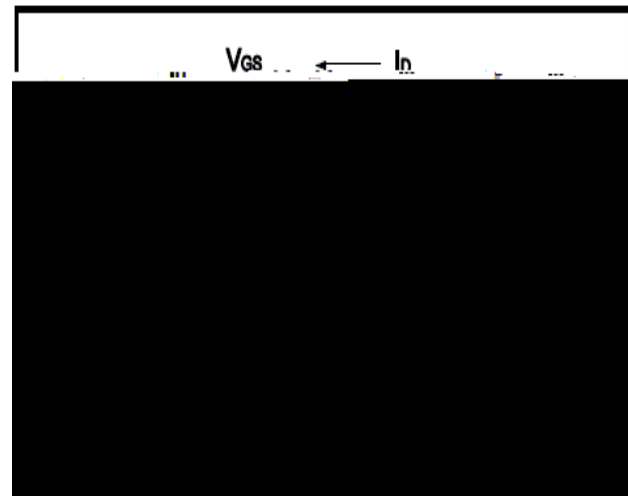

Fig.10 Gate Charge Waveform

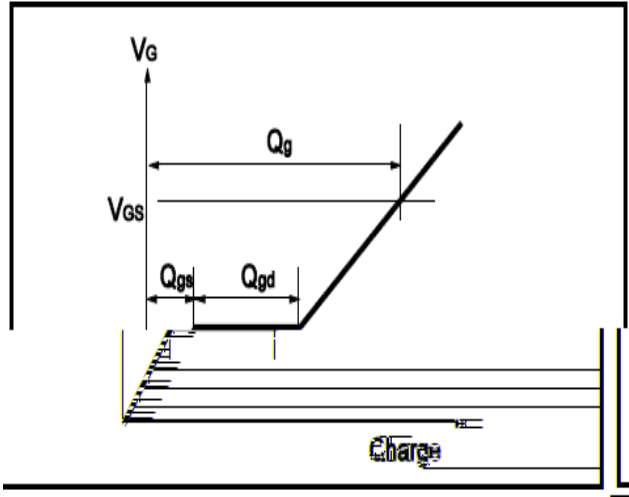
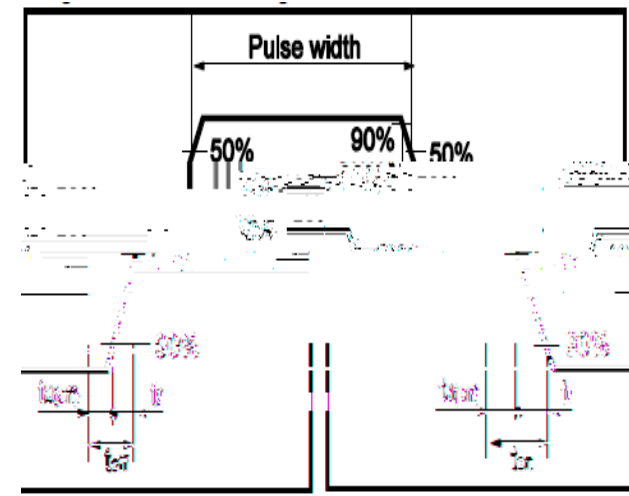

Fig.12 Gate Charge Waveform





Dimensions (TO-220F)

Unit mm
